

Contents

Preface	1
1 Product Introduction	2
1.1 Products' application	2
1.2 Products' feature	2
1.3 Operation principles	2
1.4 Principles of products' naming	3
1.5 Parameters of products	3
1.6 Products' external structures	4
2 Safety, Preparation and Examination	8
2.1 Preparation for use	8
2.2 Precautions on safety	8
2.3 Operational environment	9
3 Installation	9
3.1 Necessary conditions for installation	9
3.2 Installation environment	9
3.3 Installation steps	9
4 Startup and Commissioning	13
4.1 Introduction to the controlling panel	13
4.2 Power on	13
4.3 Commissioning	16
5 Standard Operation & Parameter Setting	24
5.1 Preparation, adjustment and inspection before operation	25
5.2 Parameter setting	25
6 Maintenance	26
6.1 Attention for maintenance	26
6.2 Maintenance schedule	27
7 Troubleshooting	27
7.1 Troubleshooting	27
7.2 Motor maintenance	29
8 Movement and Storage	30
8.1 Equipped with carton packaging	30
8.2 Storage of short time	30
8.3 Storage of long time	30
8.5 Start the machine after long-term storage	30
9 Electric Schematic Diagram	31
9.1 Electric schematic diagram	31

Preface

Thank you for buying the Continuous Band Sealer. The Manual is suitable for the model FRM-980I、FRM-980II、FRM-980III、FRMQ-980III、FRQ-980III、FRMC-980III.

This instruction manual has following content:

- Product introduction
- Precautions on safety
- Movements and storages
- Installation
- Operation and commissioning
- Maintenance
- Troubleshooting

This manual gives a description of the installation and use of the product, and it includes following contents: the product's movement, storage, installation, operation conditions, maintenance, troubleshooting and repairing.

Notice:

- Please read this manual carefully and understand it thoroughly before using.
- Make sure this manual is possessed by the operator or the managerial personnel of this product.
- Please retain this manual after reading and make sure it is available for reference if needed.
- Any questions, please contact the manufacturer or distributor.

Responsibilities:

- This manual is written carefully and for possible mistakes or the mistakes due to misunderstanding, the manufacturer does not take any responsibility.
- The manufacturer will not be responsible for the damage or problems caused by having not adopted the specified spare part.
- The manufacturer keeps the right of amendment on the parameter or parts without prior notice.
- All rights are reserved by manufacturer. And without written approval, printing of any part of this manual is forbidden. If found, the company reserves the right to pursue legal responsibilities.

Terms:

- **Sealing belt (Teflon belt):** to make the bag be out of touch of heating block to avoid influence the sealing effect.
- **Heater:** consist of copper block and heating tube

1 Product Introduction

1.1 Products' application

This sealer is suitable for sealing all kinds of plastic films, which is widely used in fields of food, medicine, chemicals, commodities and agriculture, etc. It is ideal sealing equipment for packing batch products in factories and shops.

1.2 Products' feature

- This sealer is ideal for sealing small packages, which adopts constant temperature control system and stepless speed adjusting transmission mechanism.
- It has the advantages of high efficiency for continuous sealing, reliable sealing quality, superior structure and simple operation, etc.
- The sealing direction of standard machine is from right to left. It can also be designed to seal from left to right according to customers' requirement.
- It has three types: horizontal type, vertical type and floor type. The horizontal type one is suitable for sealing packs of dry products while vertical one for powder or liquid products.
- After sealing, the pack has grid embossing or stripe embossing. Also blank smooth embossing is optional. Additional embossing roller or counter can be provided according to the customers' requirements.
- The machine works with solid-ink coder to print the colored labels while sealing. The coder is able to print highly legible letters in optional colors. And it can dry instantly with good adhesion property. The machine can print two lines in font size four (18PT) or three lines in font size five (10.5PT) at the same time in R arrange. Every line can arrange 20 characters. And the company can provide customers with special orders for T-type arrangements and multiple lines.
- It applies to sealing different plastic films made from various materials. Or it can also be customized to match with different packing lines.

1.3 Operation principles

After power supply is connected, electrothermal elements start to produce heat, which leads to rapid temperature rise of both upper and bottom heating blocks. Adjust temperature controller and speed-adjusting knob to get the required temperature and speed respectively. The sealing area of plastic packing bag is conveyed to the position between two sealing belts by conveyor belt first, then clamped by two sealing belts and delivered to the heating area. The plastic film is heated and softened. Under the pressure from pinch roller, the film binds. After this, the sealing part will be conveyed to the cooling area for cooling and forming, and then pressed by embossing roller for making stripe or grid pattern, and print the needed colored labels.

The running of transmission part of the sealer and printer is started by motor, which drives sealing belts, guiding belts and conveyor belt through gears to run synchronously, and intermittently drive the printing mechanism to work synchronously.

1.4 Principles of products' naming

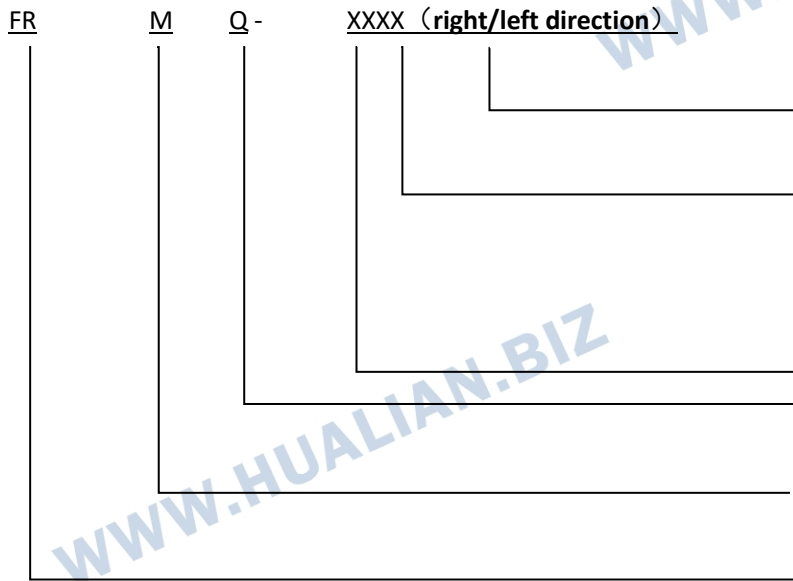

Blank means sealing from right to left

Model

- I horizontal type
- II vertical type
- III floor type

Sealing belt girth(mm)

With gas-filling device

Solid-ink colored printing

Continuous band sealer

1.5 Parameters of products

Parameter Item	Model					
	FRM-980I	FRM-980II	FRM-980III	FRMQ-980III	FRQ-980III	FRMC-980III
Voltage(V/Hz)	AC 220/50 110/60					
Driving power(W)	50			185		420
Sealing power(W)	300×2					
Printing Heating Power	40×2					40×2
Sealing speed(m/min)	0~12 (0~16)					
Sealing width(mm)	10					
Temperature control range(°C)	0~300 (°C) (Stepless adjustable)					
Printing type	Solid ink roller				Solid ink roller	
Distance from sealing center to conveyor (mm)	20~40	200~320	20~40			
Simple layer film thickness(mm)	≤0.08					
Max. single bag loading of conveyor (Kg)	≤1					
Max. overall loading of conveyor (Kg)	≤3					
External dimensions (LXWXH) (mm)	950×400×430	950×400×670	955×550×950	1050×900×900		

Net weight (Kg)	29	35	35	50	48	50
-----------------	----	----	----	----	----	----

1.6 Products' external structures



FRM-980I



FRM-980II



FRM-980III



FRMQ-980III



FRQ-980III



FRMC-980III

2 Safety, Preparation and Examination

2.1 Preparation for use

This instruction is a detailed description of the Movement, Storage, Installation, Startup, Operation condition, Maintenance, troubles & solutions and Repairing.

The installation of machine is suggested to be operated by trained person.

Pls follow the maintenance instructions

- **Before operating the machine, pls be sure to read the operation manual carefully and fully understand it.**
- **If there is any question, pls contact the supplier.**

2.2 Precautions on safety

- Pls confirm the machine voltage, frequency to prevent the accident.
- This machine is in power system of single-phase three-wire, and the yellow and green wire is protective earth wire which should be grounding and could not be removed.
- The power cord should be protected from pressing, pulling, and should be winded when it is not used.
- Do not touch the electrical devices inside the machine after the power is turned on.
- Do not touch any driving parts to avoid injury when the machine is in operation.
- Do not open the machine hull, protection cover etc. when machine is on so as to avoid pinching, scalding or electric shock.
- Do not touch the heating blocks to prevent from burns.
- When the machine is repaired, please proceed when the heating blocks are fully cool to avoid burns.
- Do not use the machine in corrosive and dusty environments.
- Do not optionally replace parts on the machine.
- Keep the inside and outside of the machine clean and remove the surface adhesive materials from the Teflon belt in time.
- Fill and exchange oil in worm-gear case regularly, and oil gear and sprocket (YP7408 semi-liquid gear oil).
- When the machine is not in use, the power supply and air supply should be switched off.
- Keep this manual properly for easy reference in the future.
- This machine is produced as per the latest technology and security standard. There may be danger or damage under improper operation. Please notice the keywords "DANGEROUS", "WARNING", "TAKE CARE".

E.g.:



DANGEROUS!

Ignorance of this notice will lead to damage even fatal accident.



WARNING!

Ignorance of this notice will lead to damage even fatal accident.



TAKE CARE!

Ignorance of this notice will lead to injury or property loss.

2.3 Operational environment

This product is designed to run under room temperature. If the environment is in bad condition (such as corrosive atmosphere, high temperature or temperature in frequent changes), please contact the manufacturer or distributor.

3 Installation

Before installation and operation, please read this manual carefully. You can get the information of the installation, starting, maintenance and operation of the machine. Supplier is not responsible for the problem caused by the operation against this manual.

Hope all client use this machine without any problem. If any question, feel free to contact supplier or dealer.

3.1 Necessary conditions for installation



Caution! Harm to machine!

Without essential condition for installation, machine will be damaged.

Be careful injured!

Please obey the essential condition for installation.

Please assure the installation environment satisfy basic safety regulations.

3.2 Installation environment

- No inflammable and explosive gas is allowed.
- Environment temperature: 5-30°C. If need operation under other temperature, please confirm with supplier or dealer first.
- Environment pressure, standard atmospheric pressure
- Assure power environment satisfy requirements (refer to nameplate).
- No inclined is an important factor of the machine successful operating.
- Leave enough space to assure good ventilation for heat dissipation. At least 10cm interspace.
- Machine cannot be exposed to heat source and steam device directly. (such as steamer, dish-washing machine or stove)
- Assure enough space to replace the easy worn spare parts.

3.3 Installation steps

- **FRM-980 Installation steps of electrical box**
- Take out the FRM-980I machine and electrical box, connect the terminal on the electrical box to the

terminal on the hull, and install the electrical box on the hull.

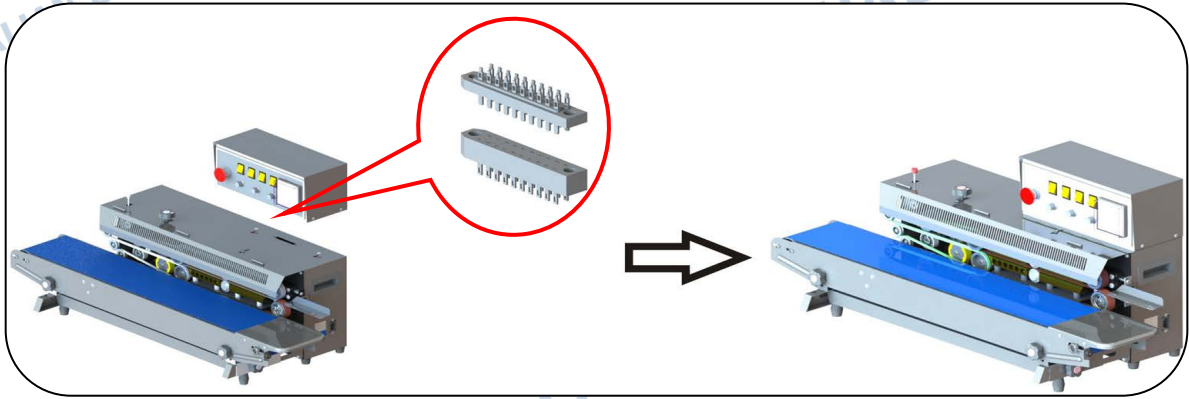

➤ **FRM-980II Installation steps**

- Take out the FRM-980II and dual axis assembly, and install one side in conveyor table (refer to the red circle part in below picture) and insert the other side into connecting shaft to finish installation.

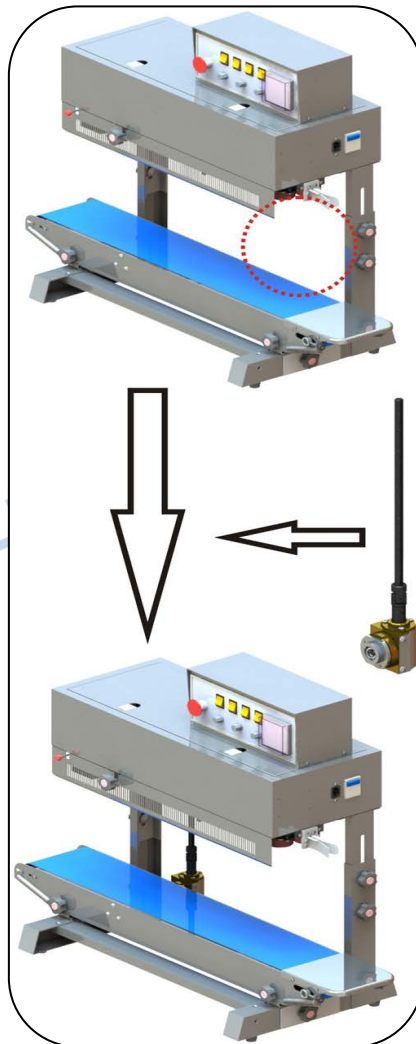

➤ **FRM-980III Installation steps**

- Take out floor type fixed support, casters, rung, fastening accessory. Install the rung on floor type fixed support, and then install four casters in the bottom.

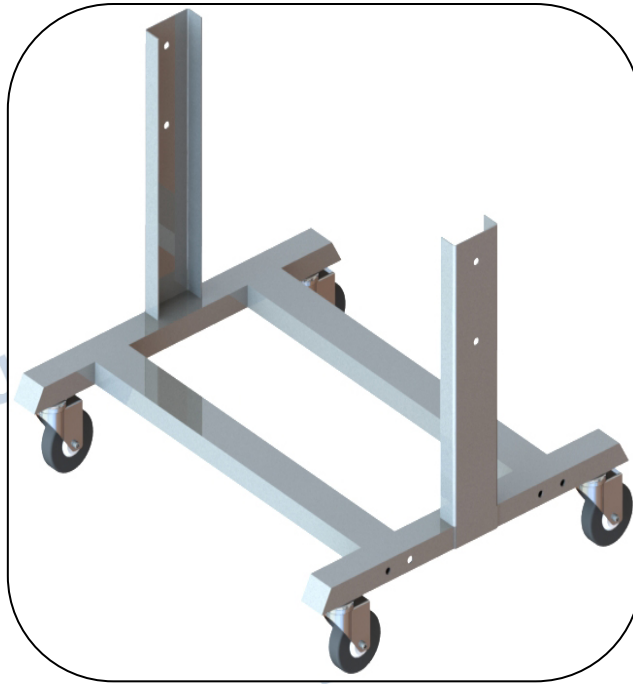

- Take out floor type fixed support, casters, rung, fastening accessory. Install the rung on floor type fixed support, and then install four casters in the bottom.

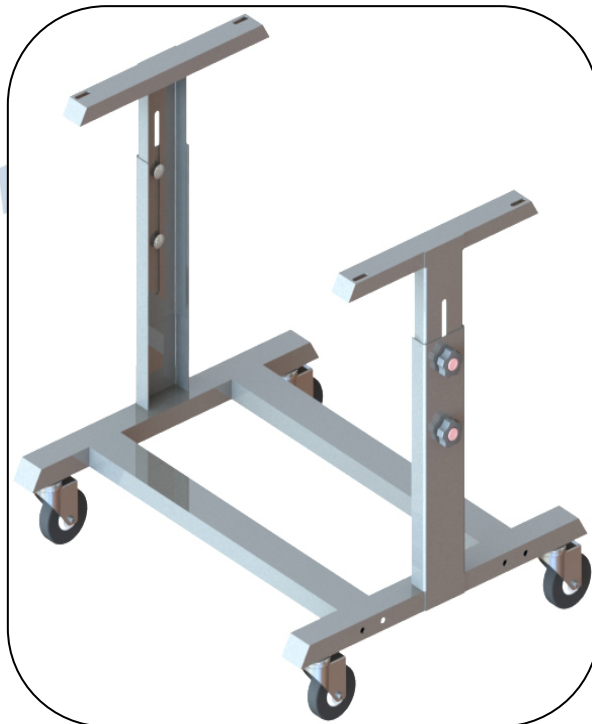

- Take out the machine FRM-980III and take out the blot in its 6 rubber feet in the bottom (refer to the red circle part in below picture). Put the machine FRBM-810III on the ready support. Then screw back those blot according to its previous position.

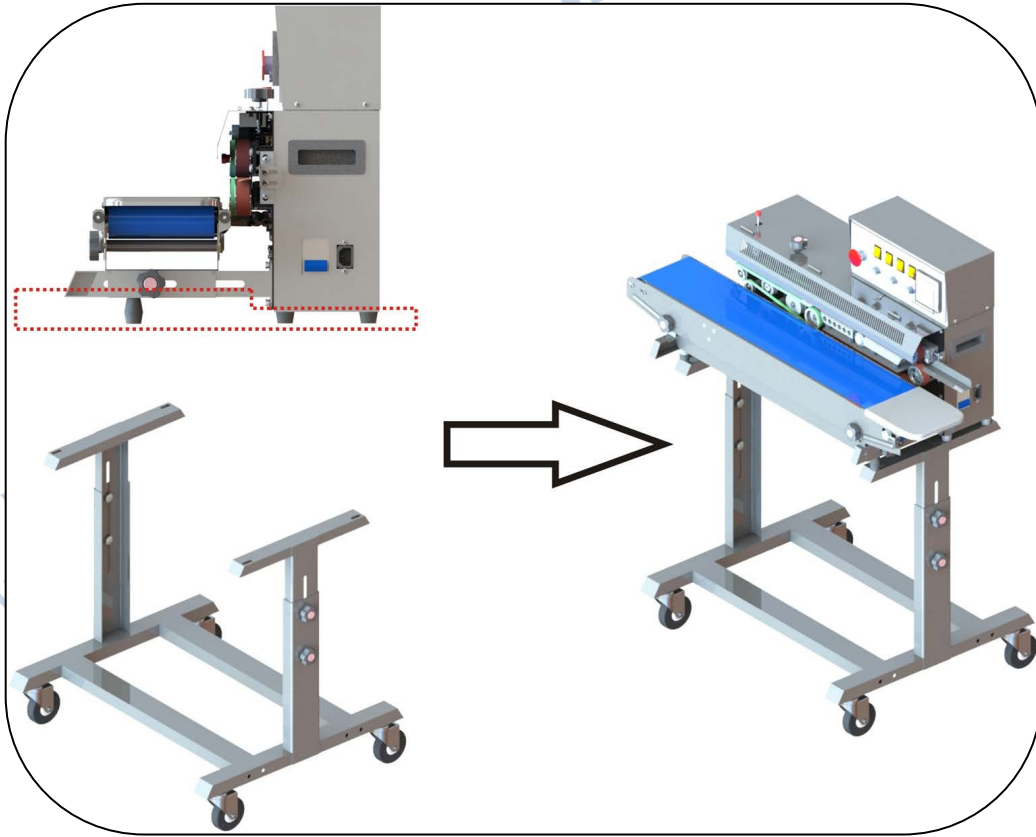

Remark: If find the installation hole of the stand has deviation, user need to loosen the knobs in the middle of stand. Fasten the knobs when match the installation hole with machine.

4 Startup and Commissioning

4.1 Introduction to the controlling panel

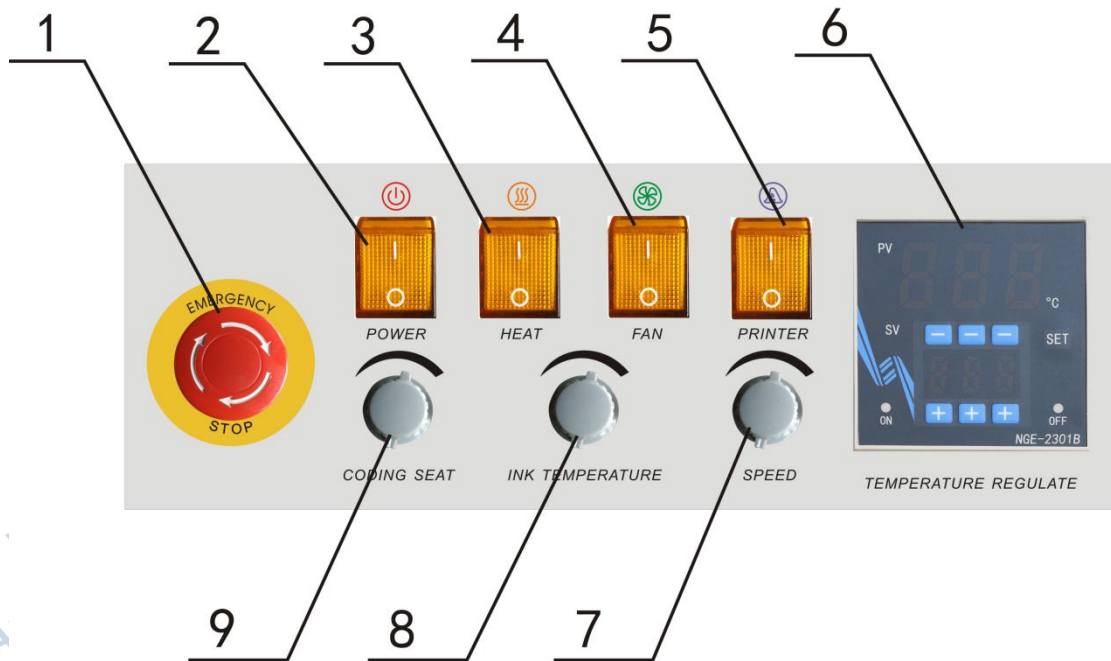

No.	Name	Description
1	Emergency Stop	Used to stop the running of machine. Press it to stop the machine at any time. After pressing, the machine will stop all the operation.
2	Power	Used to turn on or off the machine power supply.
3	Heat Sealing	Optional opening and closing heat sealing function.
4	Fan	Open or close heat sealing / Open or close fan
5	Printer	Optional opening and closing solid-ink coding function.
6	Temperature Controller	Adjust the temperature of the heating block.
7	Speed Knob	Adjust the belt speed.
8	Solid -ink Temperature	Adjust the temperature of the heating block in the solid-ink.
9	Mark Position	Adjust the printing position on the bag film.

4.2 Power on

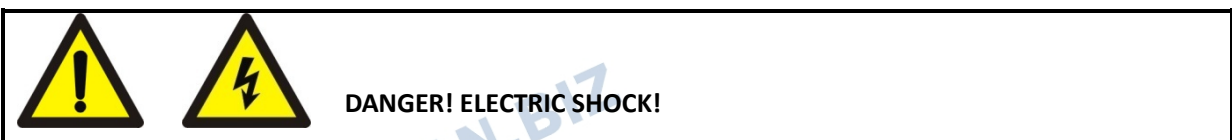

Please abide by safety operating regulations.

Via rotating the Power Switch to start the machine.

After the connection with the power supply, the indicator light will be on. And the touch display will show the home page, which means the machine is now in the state of standby, and the machine is ready to be operated.

4.2.1 Starting power supply



WARNING! ELECTRIC SHOCK!

Ensure that the socket used has protective grounding wires.

Be careful! Power mismatch will damage the machine!

Please check the power parameters of the machine by referring to the machine nameplate.

Please comply with safety guidelines and national accident prevention measures.

➤ Power/Ground

- Check whether the power supply voltage is consistent with the voltage in the machine's nameplate.
- Ensure the machine is properly connected to a grounded receptacle, so as to avoid the fire or electric shock (grounding line is the yellow green double color line).
- The cable must be free to move to avoid extrusion.
- Once the cable is damaged, please replace immediately.
- When there is machine malfunction or when the machine needs maintenance, please cut off power supply.
- If the machine will be idle for a period, please pack the cable.

4.2.2 Startup procedure

- Connect the power and press the emergency stop switch, the indicator lights up, adjust the heating speed knob, then the transmission parts run synchronously.
- Fine tune printing wheel knob, make the printing wheel rotating. Adjust it to the appropriate pressure and fix the limit screw.
- Turn on the heater switch, then the green light of temperature controller lights up. According to the material and thickness of the packing bag, adjust the temperature controller to the desired temperature. When the heating block begins to warm up, the machine shall be turned on at the same time.
- That whether it is necessary to turn on the fan for cooling depends on the material and thickness of packing bag.
- Optional opening and closing solid-ink coding function according to actual need.

- Adjust mark position to regulate the printing position on the bag film.
- Flatten and align sealing opening, then feed the bag by aligning the bag opening with the feed opening. When the bag opening is gripped by the sealing belts, which makes the bag moving forward automatically, at that moment, please do not push it in or pull it out by force, otherwise there will be irregular sealing or breakdown.
- If it is found that there is dirt attached to the sealing belt or the heating block, stop the sealer and clear it. Do not clear the dirt with hands when the temperature is high.

4.2.3 Stop operation

In order to prolong the service life of the sealer, before turning off the machine, please return the temperature-regulating knob to position 0 firstly, and turn on the fan. At the same time, the indicating temperature begins to fall and the sealing belt should still be in state of running. After several minutes later, when the temperature drops below 100°C, it is allowed to turn off the fan and main power switch.

4.2.4 Emergency stop switch

At any time, the machine stops immediately after pressing the emergency stop switch. The emergency stop switch is a self-locking switch, and it needs to be rotated by a clockwise 120 degrees to open.

4.3 Commissioning

4.3.1 Replacement and adjustment of the sealing belt

- Remove the safety cover, after the heating block cooling, rotate retaining washer by 90° on both upper heating block and upper cooling block to lift both two blocks, then loosen the springs on both embossing roller and pinch roller, meanwhile, remove the guiding belt, so as to make it ready for removing sealing belts (as below figure).

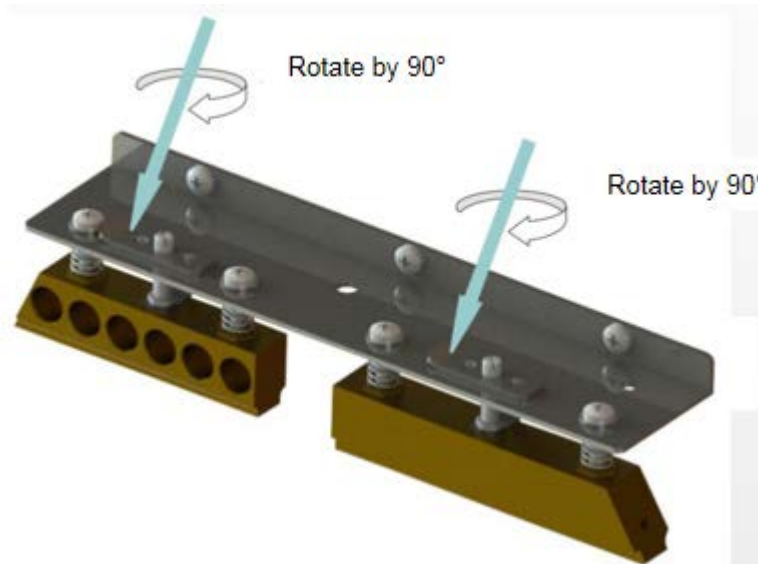

- Move the driven wheel seat (adjusting block) towards heating block, and remove the sealing belt.
- Replace it with a new sealing belt and install the guiding belt back.
- Adjust the driven wheel, heating blocks, cooling blocks, and pinch roller etc. to the original position.
- Connect the power supply to test the machine.
- Install the protection cover. When the temperature reaches the setting temperature, the machine is ready for work.

4.3.2 Forward-and-backward adjustment of conveyor table

Loosen the adjusting knobs on both sides first, and then move the conveyor table forward or backward in the long slot along the feet. Tighten the knobs on both sides after finishing the adjustment.

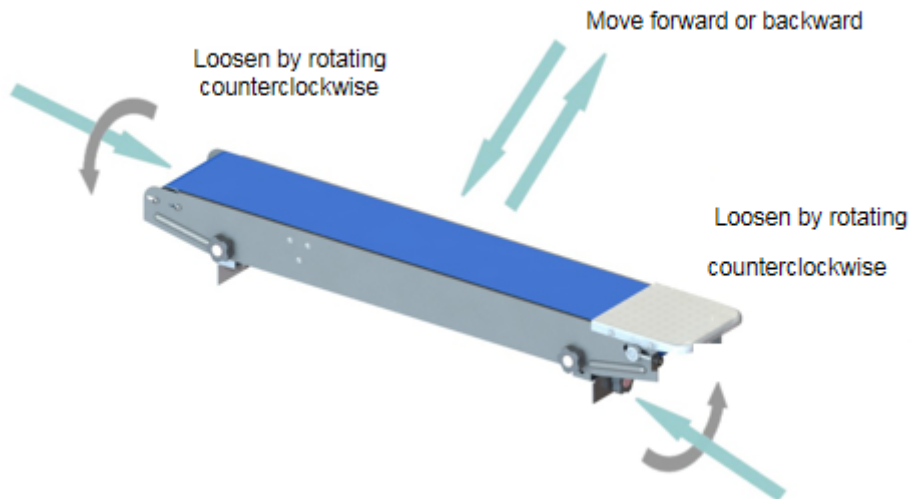

4.3.3 Adjustment of sealing belt deviation

If the sealing belt deviates, the sealing belt can be adjusted by adjusting the screws in the driven wheel seat (adjusting block) (as below figure).

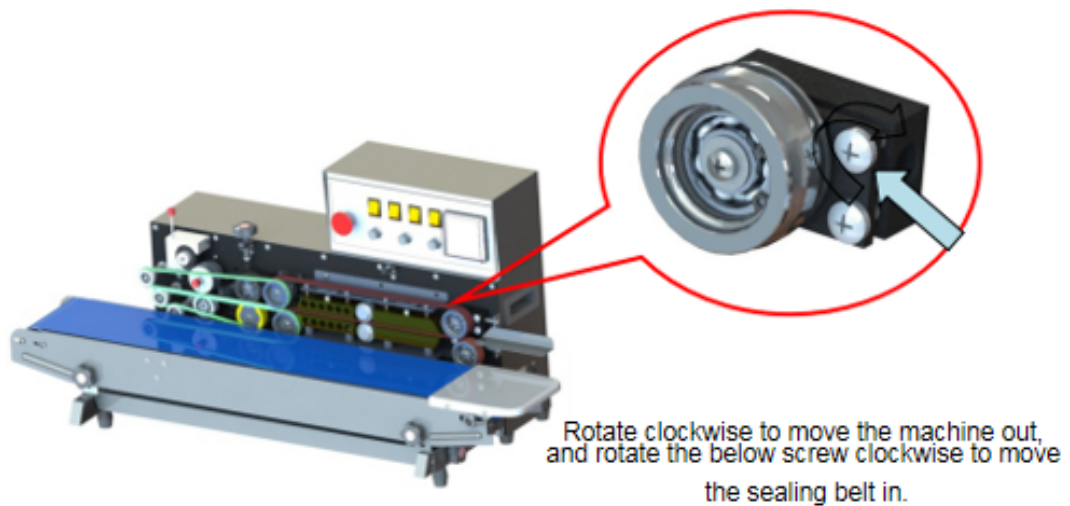

4.3.4 Adjustment of conveyor table height

According to different materials, if it is needed to adjust the height of the conveying table, adjust the conveying table height by the adjusting knob in front of the conveyor table (as below figure), and tighten it after adjustment.

WWW.HUALIAN.BIZ

WWW.HUALIAN.BIZ

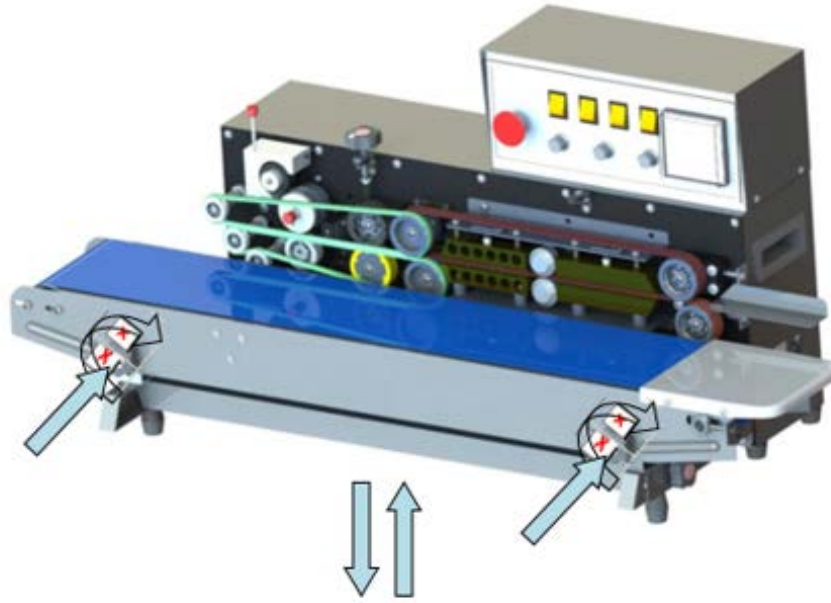

Loosen counterclockwise to adjust conveyor table height

WWW.HUALIAN.BIZ

WWW.HUALIAN.BIZ

WWW.HUALIAN.BIZ

WWW.HUALIAN.BIZ

WWW.HUALIAN.BIZ

WWW.HUALIAN.BIZ

4.3.5 Adjustment of conveyor belt running deviation

If the conveyor belt run deviation, the conveyor belt can be adjusted by adjusting knob on the right side of conveyor table (as below photo). Keep the conveyor belt under tension state when adjusting, and it is not allowed to adjust when the conveyor belt under relaxed state.

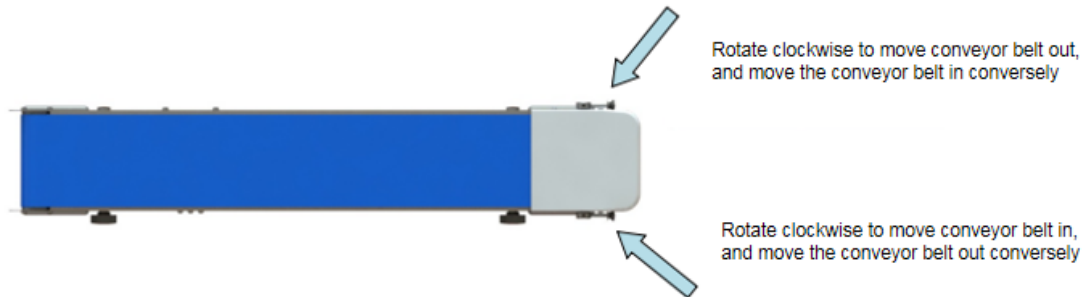

4.3.6 Pressure adjustment of embossing wheel

If there is a need to make the pattern of the embossing wheel deep or shallow, adjust the adjustment knob at the top of the embossing wheel (as below photo).

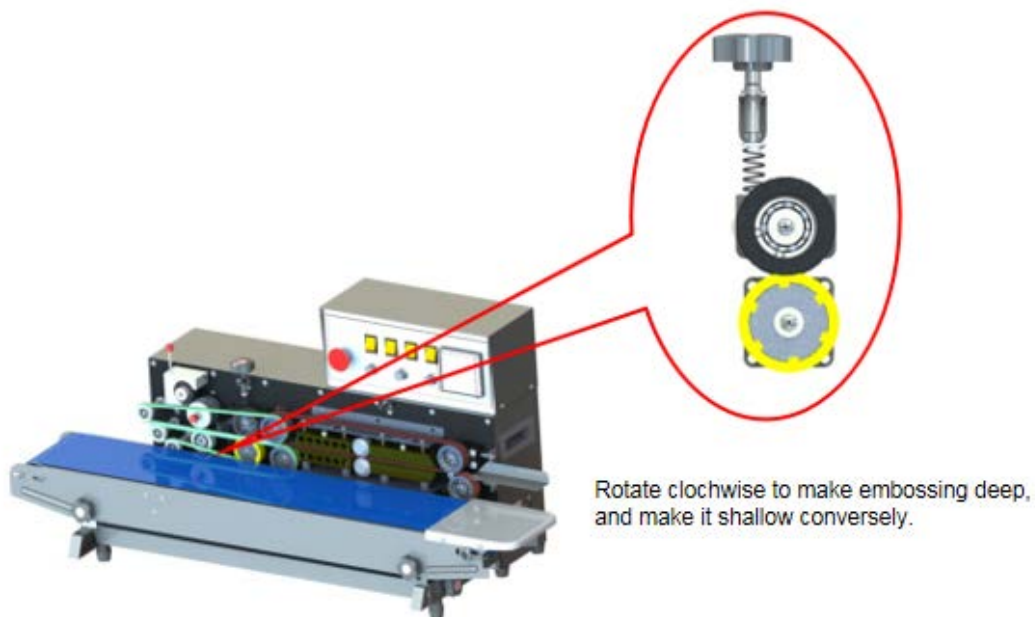

4.3.7 Printing mechanism adjustment method

- The option of character arrangement: T-type or R-type (as shown below).



T Type



R Type

- The example of character's alignment on the printing wheel (as shown below)



T Type



R Type

- Printing example of R-type

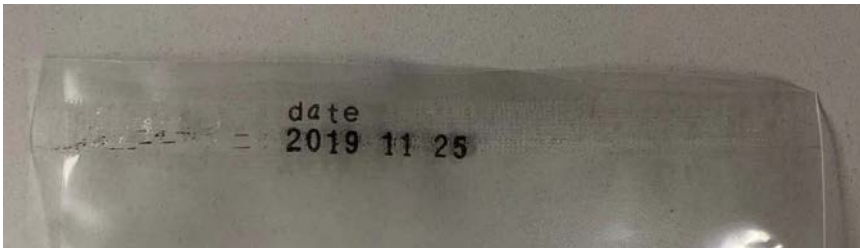

- Character replacement (see below).

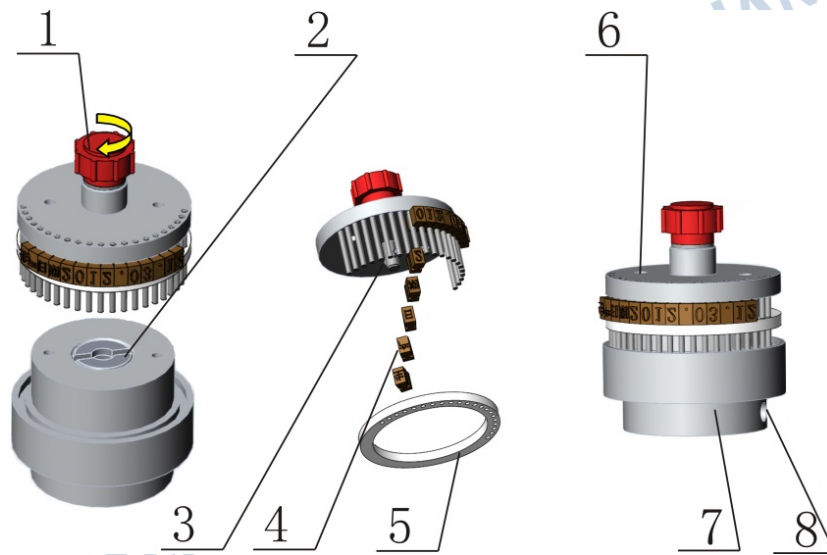

NO.	Name	Remark
1	Printing Wheel Pin	
2	Printing Wheel Shaft Cover	
3	Lateral Pin	
4	Character Kit	
5	Silicone Rubber	
6	Locating Pin	
7	Printing Wheel	
8	Printing Wheel Set Screw	

- Rotate the pin on the printing wheel cover to let the lateral pin come out of the groove, then the printing wheel shaft cover will automatically open. Take off the cover to replace the character.
- After replacing the character, press the silicone rubber, then cover the printing wheel cover, insert the lateral pin into the groove of the printing wheel shaft cover, and press the printing wheel pin and rotate to fix.

● **Adjustment of space between ink roller and character kit**

- Rotate screw (5) clockwise, then ink roller (1) will be tilted and move away from the printing wheel. Rotate screw (5) counterclockwise, the ink roller (1) will press against the printing wheel by the elastic element.
- Adjust the adjustment screw (5) of ink roller swing link, and rotate the printing wheel, then the character kit will contact with the ink roller (1). And the ink roller can be easily driven by hand.

NO.	Name	Remark
1	Ink Roller	
2	Ink Roller Heating Block	
3	Swing Link	
4	Adjust Pillar	

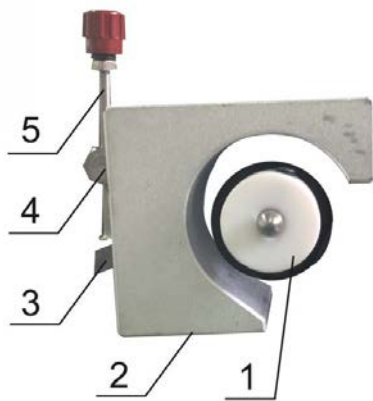

5	Adjustment Screw	
---	------------------	--

● **Pressure Adjustment of Printing Wheel and Silicone Wheel:**

There is no contact between the characters on the printing wheel and the silicone wheel when it is not working. Loosen the screw (4) on the front of the silicone wheel and rotate hexagonal nut of the eccentric wheel (3) so that the character kit in rotation can contact with the silicone wheel(2). If printing a thicker bag, it needs to be loosen more, and the pressure should not be too high, then tighten the screws when adjustment is ready. (As shown below).

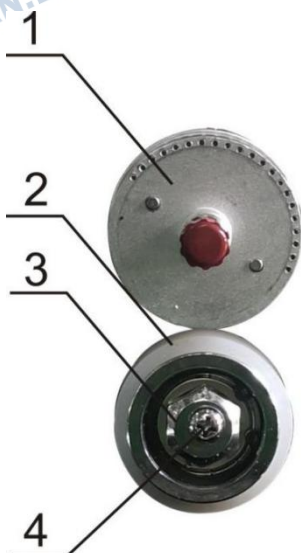

NO.	Name	Remark
1	Printing Wheel	
2	Silicone wheel	
3	Eccentric Wheel	
4	Screw	

● **Temperature Adjustment of Printing wheel and ink wheel:**

All the adjustment knob is at "0" position when the machine is shipped from the factory. Users need to adjust them according to needs. The temperature can be appropriately lower when the ink roller is first used. After a period of time, the temperature can be appropriately increased to make the deeper ink out to extend the life. When the ink roller reaches the operating temperature, use a white paper to lightly touch the outer surface of the ink roller, and it is preferable that the paper be stained with a little ink. And the set temperature must be moderate.

Model	Outside Diameter (mm)	Height (mm)
-------	-----------------------	-------------

Low temperature series 120-150°C (code 935)	Φ36	16
	Φ36	32
	Φ36	40
Mid-temperature series 135-165°C (code 932)	Φ36	16
	Φ36	32
	Φ36	40
High temperature series 150-175°C (code 930)	Φ36	16
	Φ36	32
	Φ36	40

This machine is suitable for the following types of ink roller specifications, including white, yellow, red, blue, green, brown, black and other colors. In the case of packaging bags that need to be steamed after printing, it should adopt medium-temperature or high-temperature ink rollers, and the temperature must be increased accordingly.

- **Adjustment of marking position:**

According to the length of the bag, users can set the position of the printed label by rotating the position indicator knob.

- **Adjustment of printing lines:**

Arrange characters within the set range, and then fix the characters in the needed axial position using the supplied silicon strip

4.3.8 Control panel removal method

- First, remove the back cover of the chassis;
- Second step, remove the emergency stop switch (by turning out the red knob on the emergency stop switch counterclockwise, and then turning out the silver clasp under the red knob counterclockwise), and remove the pins on the front and rear sides of the temperature controller;
- Third step, push the control panel into place in the direction of arrow A in the figure below (at this time the housing and control panel are loose), then take out the control panel as shown by arrow B.

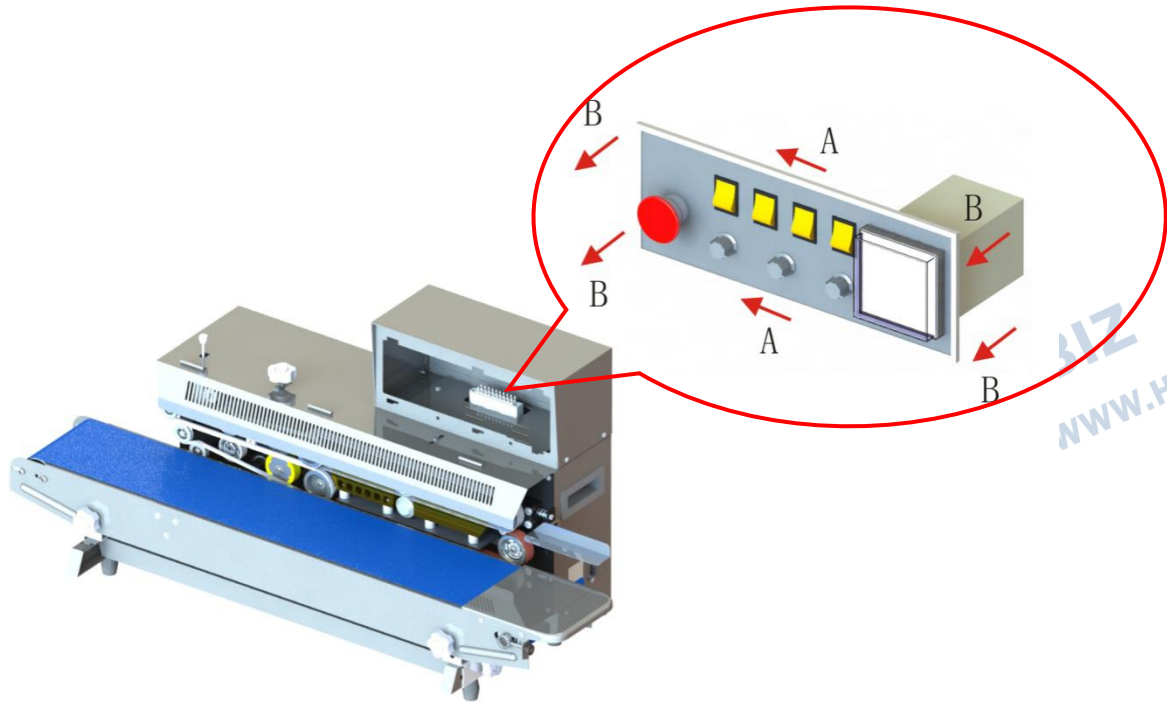

5 Standard Operation & Parameter Setting



TAKE CARE! INJURED!

Please refer to this manual to operate this machine. It is not allowed to discharge the necessary protection cover or hull.



TAKE CARE! CLAMPED!

When the machine is running, it is forbidden to put hands into the driving wheel to avoid clamping hands!



TAKE CARE! SCALD!

When sealing, the temperature outside the surface of heating block can reach over 200°C. Even after cooling, it is still with high temperature.

- If any question about operation and function of the machine, when related information is not included in this manual, please contact manufacturer or distributor.
- If machine is not running in normal situation or produces strange noise, please turn off power immediately to stop machine running and cut off power supply.
- Once in trouble, please contact manufacturer or distributor.

5.1 Preparation, adjustment and inspection before operation

- This machine is equipped with a grounded three-hole socket. The power supply used should be well grounded to ensure safety in production.
- When in first time use or when there is too long time interval after use, the electric heating element will be affected with damp, it should be operated in normal operation after preheating in low temperature for a few minutes.
- According to the bag shape and size, adjust the conveying table height and forward-and-backward position.
- According to the shape and size of the sealing line to the mouth, adjust the position (inlet).
- According to thickness of the sealing material, adjust upper and lower heating blocks, and the clearance between upper and lower cooling blocks, adjust the pressing force of retaining washer to control the clearance between the two sealing tapes, adjust clockwise to lift (increase clearance) and counterclockwise to fall (narrow clearance). The clearance between two sealing belts is equal to about the thickness of one layer of packing bags, so that the sealing fastness and embossing sharpness of the bag can be ensured and the clearance between two ends of the seal are not too long.

5.2 Parameter setting

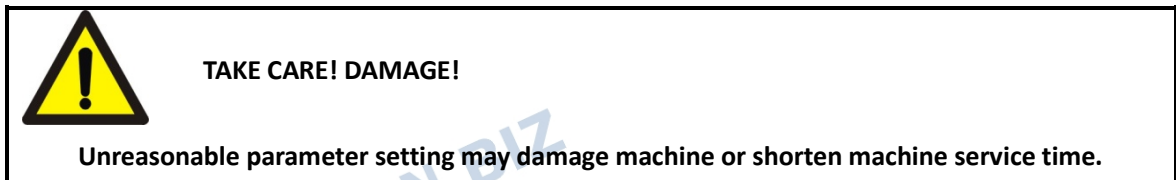

- Unreasonable parameter setting may damage the machine or shorten the service time.
- Unreasonable parameter setting may cause all procedures or sealing not to be completed correctly.
- If any question about machine's operation or function of the machine, please contact the manufacturer or distributor.
- **Speed Parameter Setting**
 - There is a speed adjusting knob in the control panel to adjust the sealing speed, clockwise rotation is to increase the sealing speed, counterclockwise rotation is to reduce the sealing speed.
- **Optimal Parameter**
 - The distance between bag sealing center to the edge of the bag is 10 ~ 20 mm.
 - Bag sealing quality is determined by the three elements of heat sealing temperature, sealing speed and pressure.
 - Temperature setting should be adjusted slowly from low to high according to the thickness of the bag.
 - Speed setting should be adjusted slowly from slow to fast according to the sealing effect.

The sealing pressure is adjusted to appropriate pressure before the machine leaving factory, and it is suitable for most product bags. If after adjusting temperature and speed, the bags cannot get the ideal

sealing effect, please adjust the belt-pressing wheel to make pressure change from low to high slowly so that to get the expected sealing effect.

➤ **Common material heat-sealing temperature reference table**

Material Name	Thickness (u m)	Recommended temperature setting (°C)	Heat-sealing speed (m/min)
LDPE	30~160	105~150	6~10
MDPE	40~120	115~120	7.2~10.2
HDPE	40~90	125~150	7.2~10.2
PP	40~60	135~160	7.2~10.2

6 Maintenance

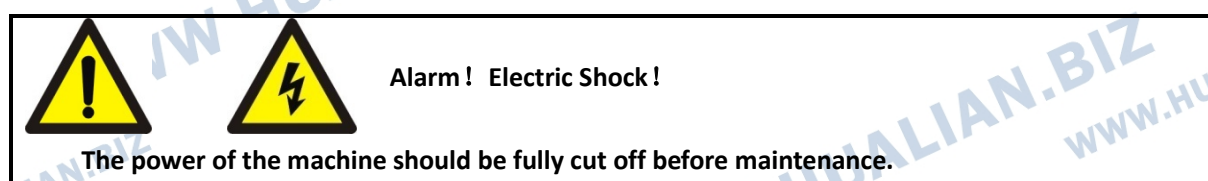

Daily maintenance to the machine is necessary to lengthen the service life of the machine and to achieve best packing effect. If the machine is frequently used (more than four hours per day), it is suggested to do professional maintenance every three month. If the machine is used less than four hours per day, it is advisable to do comprehensive maintenance very six month (according to place, environment and product). However, some users could do simple following maintenance to the machine according to their Practical needs.

6.1 Attention for maintenance

- The power of the machine should be fully cut off, the power cord should be pulled out from the socket in the wall.
- If the machine runs incorrectly or there is some abnormal noise during operation, please immediately turn off the power and contact supplier or manufacturer.
- Please do not wash the machine with high pressure washer which will do much damage to the electronic components and other spare parts in the machine.
- Please do not let the water flow into the control panel, or it will do damage to the electric circuit.
- If the operator's maintenance to the machine is not according to this manual, the manufacturer will not take responsibility for any failure or damage of the machine.

6.2 Maintenance schedule

Schedule	Contents of Maintenance
Daily	<ol style="list-style-type: none"> 1. Use the brush to remove the substance attached to the appearance of the sealing belt and guiding belt. 2. Use wet cloth to clean the appearance of the conveyor belt. 3. There is no noise or abnormal noise during motor operation.
Monthly	<ol style="list-style-type: none"> 1. Check whether the sealing belt is worn or not 2. Check whether the guiding belt is worn or not 3. Clean the carbon brush of the motor 4. the inflator filter sponge cleaning
Half a year	<ol style="list-style-type: none"> 1. Check the worn situation of the carbon brush of the motor which is suggested to change once a year 2. Adding lubricating grease to the gears which are exposed without cover.
Year	<ol style="list-style-type: none"> 1. General inspection shall be conducted according to the above items. 2. Check whether the rubber wheel is aging, and replace the rubber wheel if the aging is serious. 3. Check the temperature controller temperature rise time, temperature rise to the set value more than 10 minutes to consider replacement. 4. Check whether the switch, emergency stop, potentiometer, fan and other electrical components operate normally. 5. Check the gear, shaft, universal joint and coupling of the transmission part, add grease, and replace the parts with serious strain when necessary. 6. Clean the worm gear box and replace the lubricating oil (Great Wall brand 000# extreme pressure lithium grease lubricating oil).

7 Troubleshooting

7.1 Troubleshooting

Problem	Reason	Solution
The machine does not work	<ol style="list-style-type: none"> 1. The power is not connected. 2. The fuse is broken or high resolution circuit breaker trips. 3. The emergency stop switch is pressed but there is no reset. 	<ol style="list-style-type: none"> 1. Check the electric outlet 2. Replace the fuse and high resolution circuit breaker 3. Reset the emergency stop switch.
Conveyor belt is off-tracking	<ol style="list-style-type: none"> 1. The active axle is not parallel to the driven axle. 	<ol style="list-style-type: none"> 1. Adjust two adjusting screws of Driven Wheel Seat.
Sealing belt is easily broken	<ol style="list-style-type: none"> 1. Too much tension on sealing belt. 2. Sealing belt is off tracking. 3. Crease on sealing belt. 4. Adhesive film or other dirt attached to sealing belt surface. 	<ol style="list-style-type: none"> 1. Adjust the vertical adjusting screw on driven wheel seat, so as to make sealing belt neither too tight nor too loose 2. (see the point above) . 3. No crease on sealing belt.

	5. Sealing belt is easy to be scorched.	4. Clean the surface of sealing belt in time 5. Clearance between two heating blocks is too small or temperature is too high.
Embossing is not clear	1. Embossing wheel is worn out. 2. Pressing spring on embossing wheel is not tightened enough.	1. Replace embossing wheel. 2. Adjust the tightening spring of embossing wheel.
There is resistance when the sealing belt is conveying	The clearance between heating blocks or cooling blocks is too small, the friction is too much.	Adjust the clearance between sealing belts properly, which should be about thickness of packing bag in one layer, so as to ensure strong sealing and clear printing, but not make the two ends of sealing part extend too long.
There is block or fold phenomenon when the packing bag is conveyed to middle pressing wheel or embossing wheel	Too much pressure caused by pressing wheel or embossing wheel.	1. Adjust the pressing wheel or embossing wheel to proper pressure, so as to make the clearance between two sealing belts be about thickness of packing bag in one layer. So that not only ensure the strong sealing and clear printing, but not make the two ends of sealing part extend too long. 2. Adjust limiting screw after adjusting clearance.
Conveyor belt is off-tracking	The active roller shaft is not parallel to the driven roller shaft	1. Adjust the two adjusting screws of the driven roller shaft (rear axle).
Conveyor belt and sealing belt don't move synchronously	The conveyor belt is not tight	1. Tighten the chain of driving roller shaft (front shaft) and middle shaft properly. 2. Tighten the conveyor belt properly
Solid-ink does not work	1. The power is not connected. 2. The main control circuit board is not inserted or is in poor contact. 3. The main control circuit board is damaged.	1. Check the power line is inserted or not and the indicator light is bright. 2. Check whether the pin of circuit board is tight, and whether the wire lead dropped out. 3. Check the circuit board, and replace the components.
Printing wheel does not work	1. The contact of start sensor is stuck 2. The sensor is not clean and the photocoupler hole is blocked by	1. Remove obstacles. 2. Remove the dirt from the surface of the photocoupler hole. 3. Check and replace components.

	dust. 3.The main control circuit board is damaged. 4.The clutch pin is off or damaged. 5.Electromagnetic clutch wire is broken.	4.Repair the round pin. 5.Repair the clutch.
Printing wheel cannot stop	1.The sensor (groove optical coupling) damaged, displaced, or the surface gathered dust. 2. The main control circuit board is damaged.	1.Replace or install the positive sensor (groove optical coupling) or remove dirt from the surface of the photocoupler. 2.Check the circuit board, and replace the components.
Solid-ink heating block or printing wheel does not heat	1, electrical heated tube or wire is damaged. 2.Heating circuit board is damaged 3, Potentiometer on the knob is damaged. 4.Carbon brush holder is displaced. 5.Carbon brush holder is damaged.	1.Replace the heater. 2.Replace the circuit board. 3.Replace the potentiometer. 4.Adjust and tighten the nut. 5.Replacement.
The temperature of solid-ink heating block is out of control	Temperature control relay is damaged.	Check and replace components.
The heating position is out of control	1. Loose screws of printing wheel. 2. The main control circuit board is damaged.	1.Fasten screws 2.Check and replace components.
The noise in the gear box increases	The lubricating oil of worm gear box needs to be changed	Use Great Wall 000# super pressure lithium grease

7.2 Motor maintenance

(1) Stop and check the machine when any abnormal occurs to motor, do not use the machine until problem is solved.

(2) Dedust and clean motor regularly. Ethyl alcohol, gasoline and liquid with benzene chemicals should be avoided, otherwise it will affect the paint of motor cover.

(3) Carbon brush is designed to be used 2500 hours continuously and commutator 2500 hours. The toner on the internal of motor and surface of commutator should be cleaned every 120 hours after use. The commutator should be wiped by ethyl alcohol. Replace carbon brush and commutator immediately when they were worn out.

(4) The motor should be used indoors under normal atmospheric temperature to avoid friction, exposure to rain, and chemical corrosion, etc.. Please contact the supplier or manufacturer first if the

motor is to be used in bad condition (such as exposure to Corrosive atmosphere, temperature higher than 30°C or lower than 5°C).

8 Movement and Storage

8.1 Equipped with carton packaging

- ☑ The product is tightly packed by filler in the carton.

Note: When the machine is palletizing on the pallet, the maximum height should not exceed 5 layers.

- ☑ Make sure the wrapping film is wrapped around the machine reliably.
- ☑ Please follow the direction of the carton arrow for transportation. Do not handle it by hand.
- ☑ When palletizing the product code, use a forklift to move the machine.

Note: The machine is equipped with a conveyor table. Hold the handle when moving the machine. Do not support the transfer table.

8.2 Storage of short time

- Turn off the power button, unplug the power cord, pack up the power cord.
- Clean the dust.
- If possible, cover it with the plastic bag to keep it from dust.
- Store it in a dry, dust-free and shockproof room.

8.3 Storage of long time

When the machine leaves the factory, it has been dealt with necessary anti-rust treatment, so there is no need to add more preservative oil to the machine. If the condition of the storage is poor (the surrounding environment is corrosive, higher or frequently changing temperature), it is suitable to add more preservative oil to the machine. If there is any question, please feel free to contact supplier or manufacturer.

- Turn off the power button, unplug the power cord, pack up the power cord.
- Clean the dust.
- cover it with the plastic bag to keep it from dust.
- If possible, please pack it as original.
- Store it in a dry, dust-free and shockproof room.

8.5 Start the machine after long-term storage

Please refer to the instruction of "Installation and Starting" in this manual.

9 Electric Schematic Diagram

9.1 Electric schematic diagram

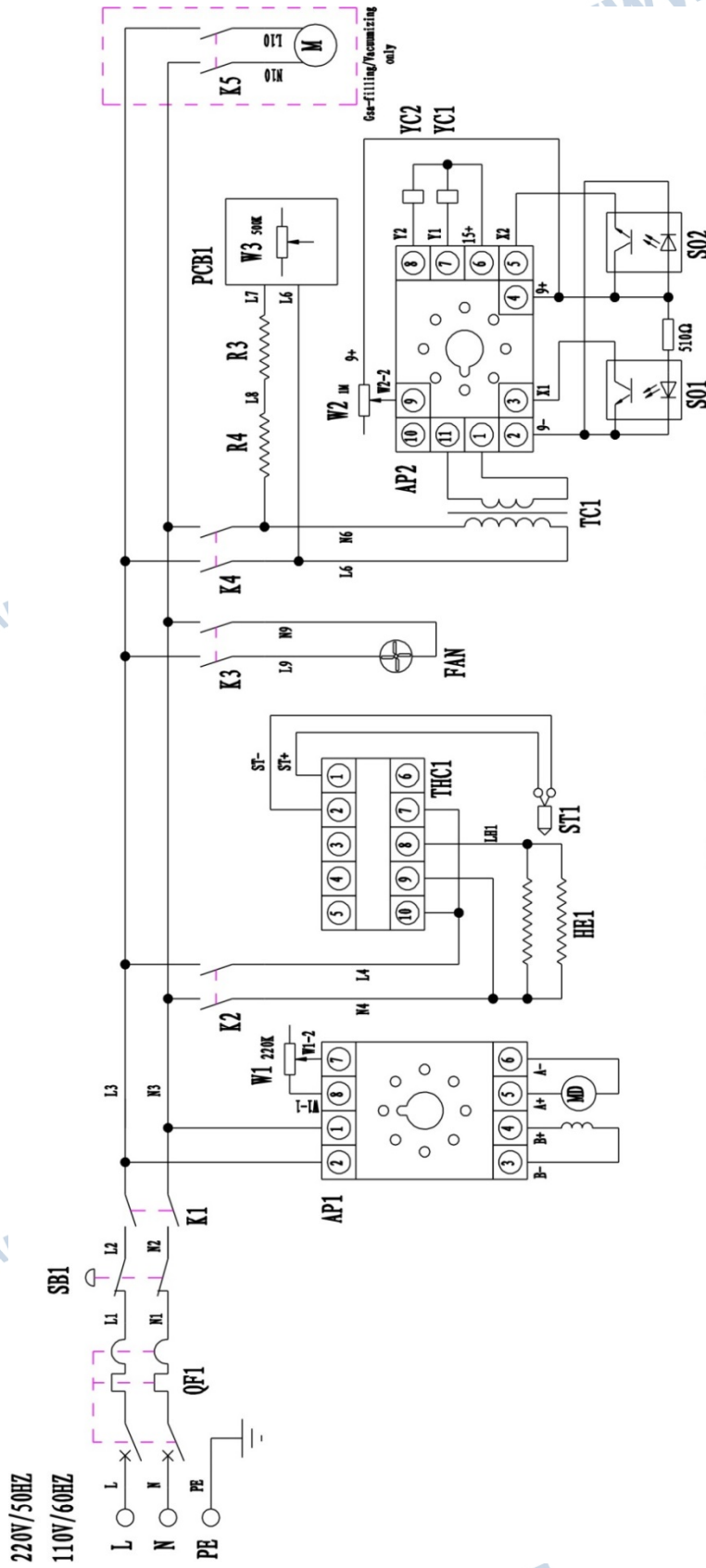

Electrical Diagram

- QF1-High Rupture Switch SBI-Emergent Stop Switch K1-Power Switch K2-Heat-sealing Switch
- K3-Fan Switch K4-Printing Switch K5-Gas-filling/Vacuumizing Switch W1-Speed Adjustment
- W2-Marked Position Adjustment W3-Ink-roller temperature EH1-Heat-sealing Heating Pipe
- R3, R4-Ink-roller Heating Pipe MD-Speed-adjusting Motor M-Gas-filling/Vacuumizing Machine
- FAN-Fan TC1-Transformer YC1-Magnetic Clutch YC2-Magnetic Brake SQ1-Groove Sensor
- SQ2-Photoelectric Sensor THC1-Temperature Controller ST1-Thermoelectric Couple
- AP1-Speed-adjusting Plate AP2-Main Controlling Plate PCB1-Temperature-adjusting Plate